

PULPMATE 650



RECOMMENDED HYDRAULIC CONTROLS:

Purpose Built Rexroth Control Valve Bank or OEM stackable valves
Rotation: Electric (Joystick Button)
Beak: Electric (Joystick Button)
Saw: Hydraulic (Footpedal)
Float Head Rotation: Electric (Joystick Button)
Float Bucket Cylinder: Electric (Joystick Button)
Float Rotation & bucket cyl: Electric (Joystick Button)

ROTATION SYSTEM:

Continuous in either direction
Heavy Duty Slew Ring
Two Rexroth MCR20 Motors
Heavy Duty Pinion Gears
Rotation Torque: 73,400 ftlb

HYDRAULIC REQUIREMENTS:

Pressure: 300 Bar (Minimum: 220 Bar)
Flow: 220 L/Min (Minimum: 180 L/Min)

WEIGHT:

Standard 2 Motor Forestry Head—
3 Motor Forestry Head—4300kg

SPECIFICATIONS:

Height: 2100mm

Width

Beak Open: 1975mm

Beak Closed: 1600mm

Length: 1960mm

Clamping Diameter: 160-1200mm

Minimum Stump Height: 52mm (2")

Clamp Cylinder Bore: 4"

No. of Cylinders: 2

SAW SPECIFICATIONS:

Cutting Capacity: 50-1100mm (2"-44")

Bar length: 52"

Chain Type: 3/4" Pitch

Saw Motor: Rexroth A2FM45

Saw Rotate Motor: MSY400

Chain Speed: 3000-3200 RPM

Saw Bar Rotation: 204 degrees

Bar Lubrication: Automatic

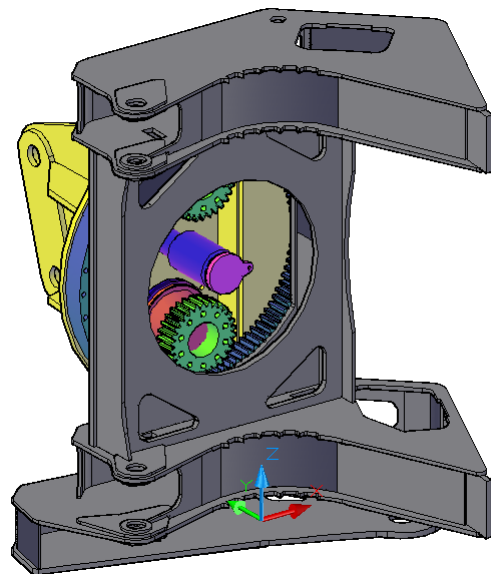

3/217 Colchester Road KILSYTH VIC 3137

Ph: 03 9761 4155

Fax: 03 9761 4947

Email: info@hardwoodforestproducts.com.au

Web: www.hfpaust.com.au